



Surge and Fire Protection

Arresters with SCI Technology for D.C. Circuits





Surge Arresters with SCI Technology for D.C. Circuits

Surge and fire protection for photovoltaic systems...

DEHN globally protects photovoltaic systems in the kilowatt to megawatt range against interruption and failure caused by lightning currents and surges. These systems require special protection especially on the d.c. side. The direct current generated by the PV modules poses a considerable challenge to the switching devices. During switching operations, the characteristic of these PV current sources can cause dangerous arcs in surge protective devices which must be handled. The EN 50539-11 test standard therefore requires to test the short-circuit current rating I_{SCPV} for surge protective devices used in PV systems. The maximum d.c. short-circuit current of the PV system must not exceed the typical I_{SCPV} value of the arrester.

... thanks to arresters with SCI technology from DEHN

DEHN is the only company that offers surge arresters with the innovative Short Circuit Interruption (SCI) technology. This patented technology provides maximum safety and prevents fire. The specifically dimensioned fuse integrated in the short-circuit path ensures safe disconnection of short-circuit currents in case of overload at any time. Moreover, the Y circuit of DEHN arresters has proven its worth over many years. The interaction of the SCI technology and the Y circuit ensures reliable surge protection – and thus maximum operational reliability and fail-safe performance.

DEHN surge arresters with SCI technology – made in Germany –

- saves additional backup fuses up to the I_{SCPV} value
- fulfils customer needs and international standards for surge protective devices
- provides excellent surge and fire protection
- offers permanent active protection

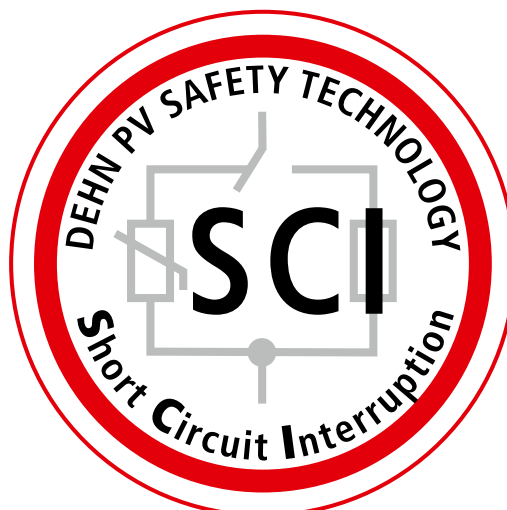



Requirements on arresters for use in PV systems depending on the time

The function of fuses **1** in PV systems with central inverters is to protect against return currents. The maximum available current depends on the actual radiation. In certain operating states **2** which depend on the time of day these fuses only trip after some minutes. Therefore, surge protective devices in generator junction boxes must be dimensioned for the possible total current (operating current and return current) and must be independently disconnected in case of overload without arc formation.

Conclusion: $I_{SCPV} > I_{max}$ PV system

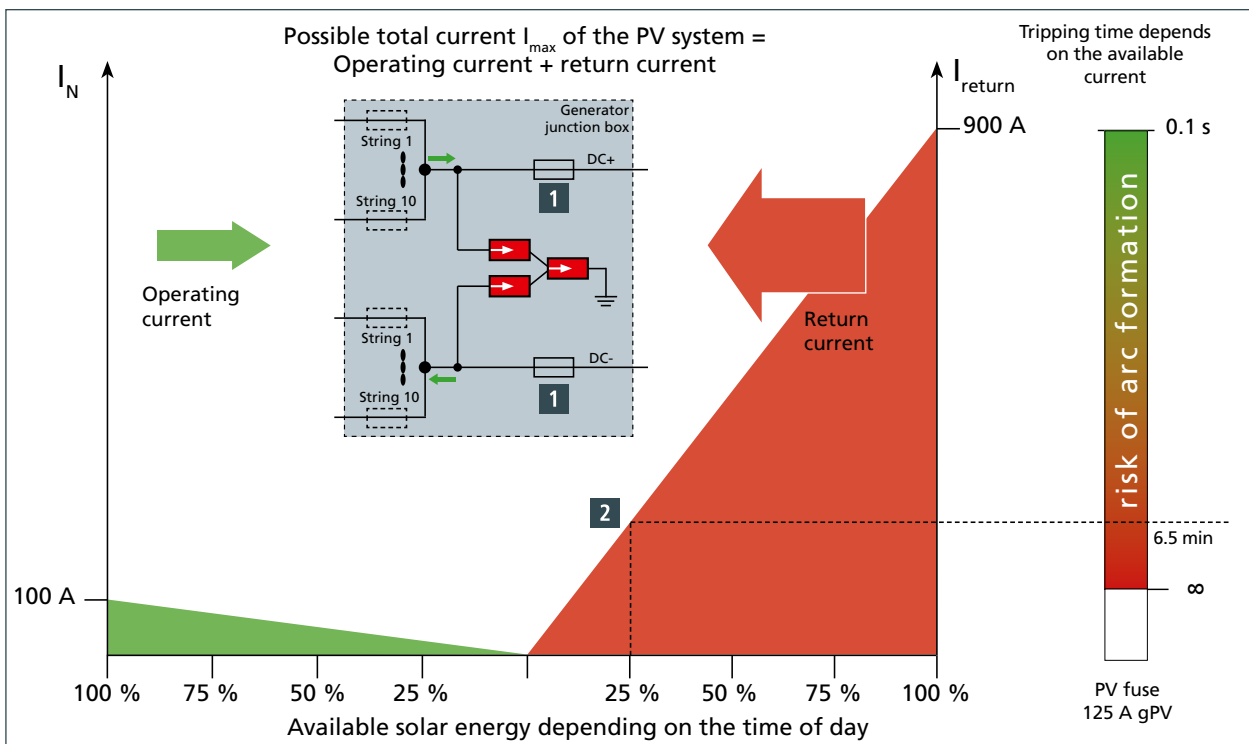



Selection of surge arresters for use in PV systems

Roof-mounted and ground-mounted PV systems are equipped with string or central inverters. Correctly dimensioned surge protective devices (SPDs) combine surge protection, personal protection and fire protection in a single device.

The following criteria are relevant for the selection of d.c. arresters:

- Place of installation and distance from terminal equipment
- SPD class: type 1 or type 2
- Earthing of live conductors
- Maximum short-circuit current I_{SCPV}

The short-circuit current is extremely important due to the special characteristic of the d.c. voltage sources of the PV system. The following applies to the selection of an arrester: The maximum d.c. short-circuit current of the PV system must not exceed the short-circuit current rating of the arrester.

The datasheet of surge protective devices specifies the I_{SCPV} value determined according to the EN 50539-11 standard. I_{SCPV} is the short-circuit current rating for which the surge protective device is dimensioned. This value must be greater than the maximum short-circuit current of the PV system:

$$I_{SCPV} > I_{max} \text{ PV system}$$

String inverters are used for all PV systems ranging from small rooftop systems to large solar parks in the multi-megawatt range. Installation devices for protecting the d.c. side against surges (at least type 2 arresters) are required for each MPP input. They are either connected upstream of the inverters in generator junction boxes or are already integrated in the string inverters. D.c. short-circuit currents typically do not exceed 100 A.

Central inverters frequently with ratings of 1 MW are mainly used in solar parks. The d.c. lines from the field are routed in parallel to a common busbar. Several hundred amperes of direct current accumulate here. Overvoltage pulses from the entire area are centrally collected on the busbar. Correctly dimensioned surge protective devices protect the input circuits from damage and increase the service life and availability of the inverter.

The generator junction boxes used for these systems are interconnected in parallel via the central inverter. The return currents must be safely discharged even if a surge arrester is overloaded. The resulting short-circuit current must not exceed the short-circuit current rating I_{SCPV} of the arrester.

DEHN has the optimal surge arresters for every application. The table on page 6 allows to select a suitable arrester for d.c. circuits.





For every application: SCI arresters from DEHN

String inverter (SIV) < 200 A

- PV direct currents of less than hundred amps
- In some cases with a generator junction box connected in series
- Short-circuit current rating I_{SCP} of the SPDs according to the maximum input current of the SIV

Central inverter (CIV) > 200 A

- PV direct currents of some hundred amps
- Parallel use of several multistring generator junction boxes
- Short-circuit current rating I_{SCP} of the SPDs according to the maximum input current of the CIV

		CIV central inverter	GJB generator junction box for central inverter	SIV string inverter	GJB generator junction box for string inverter								
Type 1 + Type 2	<p>NEW: DEHNcombo YPV SCI</p> <p>This compact type 1 and type 2 arrester is a cost-effective solution for roof-mounted and ground-mounted PV systems. Four modules. For 600 V, 1000 V, 1500 V.</p> <table border="1"> <thead> <tr> <th>Type</th> <th>Part No.</th> </tr> </thead> <tbody> <tr> <td>DCB YPV SCI 600 FM</td> <td>900 065</td> </tr> <tr> <td>DCB YPV SCI 1000 FM</td> <td>900 066</td> </tr> <tr> <td>DCB YPV SCI 1500 FM</td> <td>900 067</td> </tr> </tbody> </table>  <p>$I_{SCP} = 1000 \text{ A}$</p>	Type	Part No.	DCB YPV SCI 600 FM	900 065	DCB YPV SCI 1000 FM	900 066	DCB YPV SCI 1500 FM	900 067	✓	✓	✓	✓
	Type	Part No.											
DCB YPV SCI 600 FM	900 065												
DCB YPV SCI 1000 FM	900 066												
DCB YPV SCI 1500 FM	900 067												
Type 2	<p>DEHNguard® M YPV SCI</p> <p>Universal type 2 arrester for PV systems of any size, configuration and operating voltage from 600 V to 1200 V.</p> <table border="1"> <thead> <tr> <th>Type</th> <th>Part No.</th> </tr> </thead> <tbody> <tr> <td>DG M YPV SCI 600 FM</td> <td>952 516</td> </tr> <tr> <td>DG M YPV SCI 1000 FM</td> <td>952 515</td> </tr> <tr> <td>DG M YPV SCI 1200 FM</td> <td>952 517</td> </tr> </tbody> </table>  <p>$I_{SCP} = 1000 \text{ A}$</p>	Type	Part No.	DG M YPV SCI 600 FM	952 516	DG M YPV SCI 1000 FM	952 515	DG M YPV SCI 1200 FM	952 517	✓	✓	✓	✓
	Type	Part No.											
	DG M YPV SCI 600 FM	952 516											
	DG M YPV SCI 1000 FM	952 515											
	DG M YPV SCI 1200 FM	952 517											
	<p>DEHNguard® S PV SCI</p> <p>This single-pole surge protective device is ideally suited for directly earthed PV circuits.</p> <table border="1"> <thead> <tr> <th>Type</th> <th>Part No.</th> </tr> </thead> <tbody> <tr> <td>DG S PV SCI 150 FM</td> <td>952 556</td> </tr> <tr> <td>DG S PV SCI 600 FM</td> <td>952 555</td> </tr> </tbody> </table>  <p>$I_{SCP} = 1000 \text{ A}$</p>	Type	Part No.	DG S PV SCI 150 FM	952 556	DG S PV SCI 600 FM	952 555	✓	✓	✓	✓		
Type	Part No.												
DG S PV SCI 150 FM	952 556												
DG S PV SCI 600 FM	952 555												
<p>DEHNguard® YPV SCI - compact</p> <p>Compact type 2 arrester designed for protecting the d.c. side of string inverter systems against surges.</p> <table border="1"> <thead> <tr> <th>Type</th> <th>Part No.</th> </tr> </thead> <tbody> <tr> <td>DG YPV SCI 600</td> <td>950 531</td> </tr> <tr> <td>DG YPV SCI 1000</td> <td>950 530</td> </tr> </tbody> </table>  <p>$I_{SCP} = 200 \text{ A}$</p>	Type	Part No.	DG YPV SCI 600	950 531	DG YPV SCI 1000	950 530	—	—	✓	✓			
Type	Part No.												
DG YPV SCI 600	950 531												
DG YPV SCI 1000	950 530												
<p>DEHNguard® ME YPV SCI</p> <p>Maximum performance, safety and availability for a new generation of PV power plants with an operating voltage up to 1500 V.</p> <table border="1"> <thead> <tr> <th>Type</th> <th>Part No.</th> </tr> </thead> <tbody> <tr> <td>DG ME YPV SCI 1500 FM</td> <td>952 525</td> </tr> </tbody> </table>  <p>$I_{SCP} = 1000 \text{ A}$</p>	Type	Part No.	DG ME YPV SCI 1500 FM	952 525	✓	✓	—	—					
Type	Part No.												
DG ME YPV SCI 1500 FM	952 525												
<p>DEHNguard® PCB</p> <p>Base allows to directly integrate type 2 arresters on printed circuit boards, e.g. inverters, monitoring systems.</p> <table border="1"> <thead> <tr> <th>Type</th> <th>Part No.</th> </tr> </thead> <tbody> <tr> <td>DG PCB PV SCI 500 FM</td> <td>952 751</td> </tr> <tr> <td>DG PCB PV 500 FM</td> <td>952 741</td> </tr> </tbody> </table> 	Type	Part No.	DG PCB PV SCI 500 FM	952 751	DG PCB PV 500 FM	952 741	—	✓ monitoring	✓	—			
Type	Part No.												
DG PCB PV SCI 500 FM	952 751												
DG PCB PV 500 FM	952 741												



SCI technology ensures maximum safety and fire protection

SCI stands for **Short Circuit Interruption** and thus for all DEHN surge arresters with a three-step d.c. switching device.

Surge protective devices have an integrated disconnecter which isolates in case of overload. Insufficient results are achieved by classical methods of activating the disconnecter at the d.c. characteristic of PV sources of current. Due to the formation of an internal arc, damaging of the SPD can not be excluded. In order to prevent this, the disconnecter is combined with a bypass path. In case of overload the disconnecter will be activated and any arc will be quenched on the low-resistance bypass path. The integrated fuse interrupts the flow of follow current and a safe electrical isolation of the arrester is achieved.

DEHN SCI arresters provide a safe protection also in case of overload due to the combined disconnecting and short-circuiting device and thus an effective surge protection which meets the highest requirements with regard to personal and fire protection.

Switching phases:

If the disconnecter is activated (1) PV follow currents change over to the bypass current path of the arrester. Arising arcs will be directly quenched (2). The fuse which is integrated in the bypass interrupts the d.c. current flow (3).

This operating principle of DEHN SCI arresters ensures surge protection combined with maximum disconnection safety in case of overload.

SPD: Surge protective device

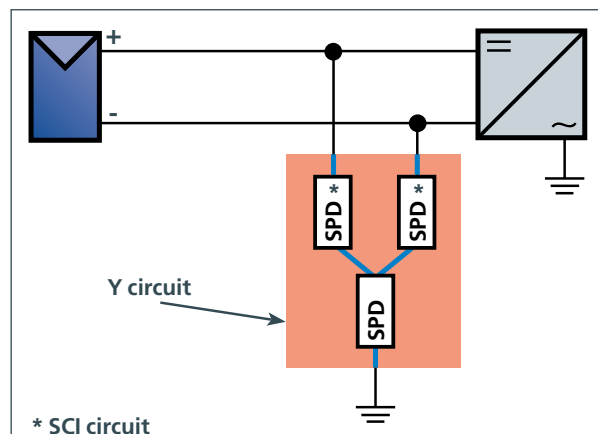

Proven, fault-resistant Y circuit of d.c. PV circuits

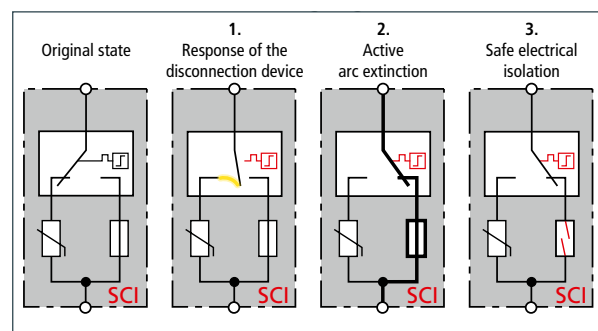

Switching phases of the d.c. switching device (SCI)



Comprehensive protection of photovoltaic systems

DEHN offers a complete product range which protects from damage due to lightning and overvoltages. The Red/Line products protect the a.c. and d.c. side of the inverter. The Yellow/Line surge protective devices protect the data flow. Also in the field of earthing and external lightning protection, DEHN products provide sophisticated solutions.

DEHNventil® M ... 255 FM

The wave breaker function of this type 1 spark-gap-based combined arrester combines maximum lightning current carrying capability and maximum coordination with inverters on the a.c. side.



Type	Part No.
DV M TNC 255 FM	951 305
DV M TNS 255 FM	951 405
DV M TT 255 FM	951 315

BLITZDUCTOR® XTU

The actiVsense® technology automatically detects the operating voltage and allows universal use for 4 to 20 mA, RS 485 and telecommunication.



Type	Part No.
BXTU ML4 BD 0-180	920 349
base part BXT BAS	920 300

HVI® Conductor

Since the special coating of the HVI®Conductor prevents lightning-induced creepage discharges, down conductors can be routed next to electrical installations.



Type	Part No.
HVI®Conductor III	819 022

UNI earthing clamp

A stainless steel intermediate element prevents contact corrosion, thus creating reliable connections of different conductor materials for many years.

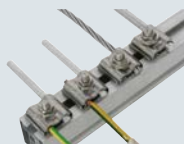

Type	Part No.
UNI earthing clamp	540 250

Protective gloves

The arc-fault-resistant protective gloves tested to IEC 61482-1-1 and IEC 61482-1-2 provide excellent wearing comfort during installation and maintenance.



Type	Part No.
APG 10	785 798

other sizes available



DEHN arresters with SCI technology protect photovoltaic systems all over the world

On all continents and under very different climatic conditions, DEHN SCI arresters protect PV systems in the gigawatt range from interruption and failure caused by lightning current and surges. DEHN arresters with SCI technology are internationally approved. They withstand extreme climatic conditions and can thus be used in any climate zone.

As a leading manufacturer of lightning and surge protection for PV systems, we have been setting trends in this industry for more than two decades. The DEHN sales team in the German headquarters and 17 international subsidiaries and offices as well as our partner network support PV projects on site – in more than 70 countries worldwide.

Examples of PV systems protected by DEHN SCI arresters representing some hundred thousand systems worldwide:

- 10 MW_p solar power plant from Gehrlicher Solar in Helmering, Germany
- 2,5 MW_p PV solar power plant from Meridionale Impianti in Palermo, Italy
- 3 MW_p PV solar power plant in Yongam, Korea
- 20 MW_p Dongtai PV solar power plant, Dongtai City, Jiangsu Province, China
- Systems with inverters from ABB Ltd, Zurich, Switzerland
- Systems with inverters from SMA Solar Technology AG, Niestetal, Germany
- Systems with inverters from Power One, Terranuova Bracciolini, Italy
- Systems with inverters from Solectria Renewables LCC, Lawrence, Massachusetts, USA



**Surge Protection
Lightning Protection
Safety Equipment
DEHN protects.**

DEHN + SÖHNE
GmbH + Co.KG.

Hans-Dehn-Str. 1
Postfach 1640
92306 Neumarkt
Germany

Tel. +49 9181 906-0
Fax +49 9181 906-1100
info@dehn.de
www.dehn.de



Protection of photovoltaic systems

DEHN, DEHN logo, actiVsense, BLITZDUCTOR, DEHNguard, DEHNventil, HVI, Red/Line are protected by German Trademark, by Community Trademark (EU) and/or are registered trademarks in other countries. We accept no liability for technical modifications, misprints and errors. Illustrations are not binding.